

DOWN OUTWARD OPENING WINDOW FOR BOLTING, TRAPEZOID

model: W-ODB-F-TR

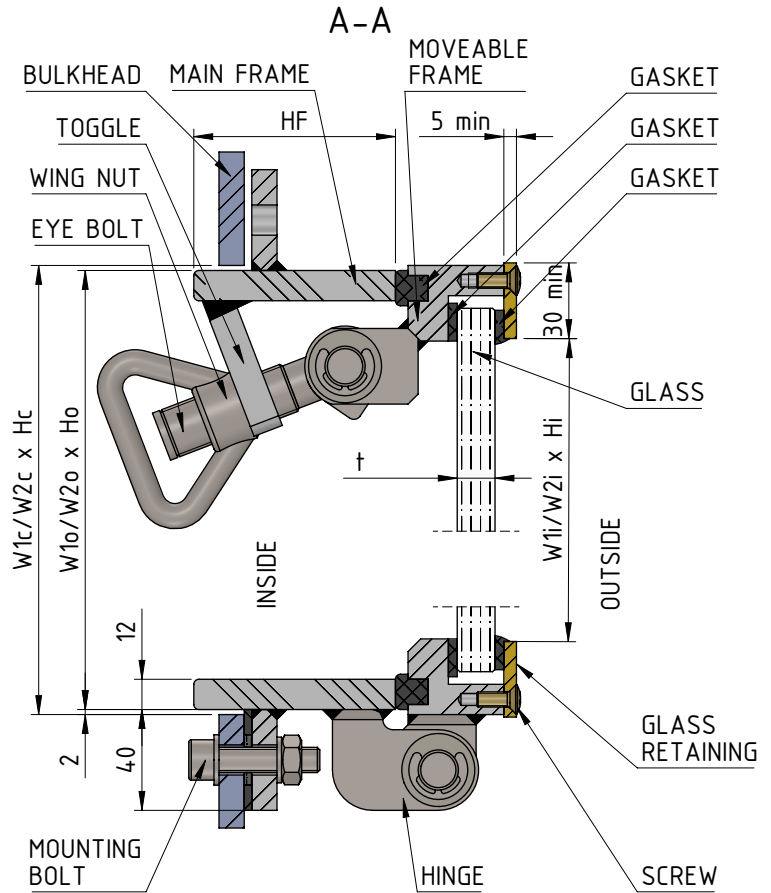
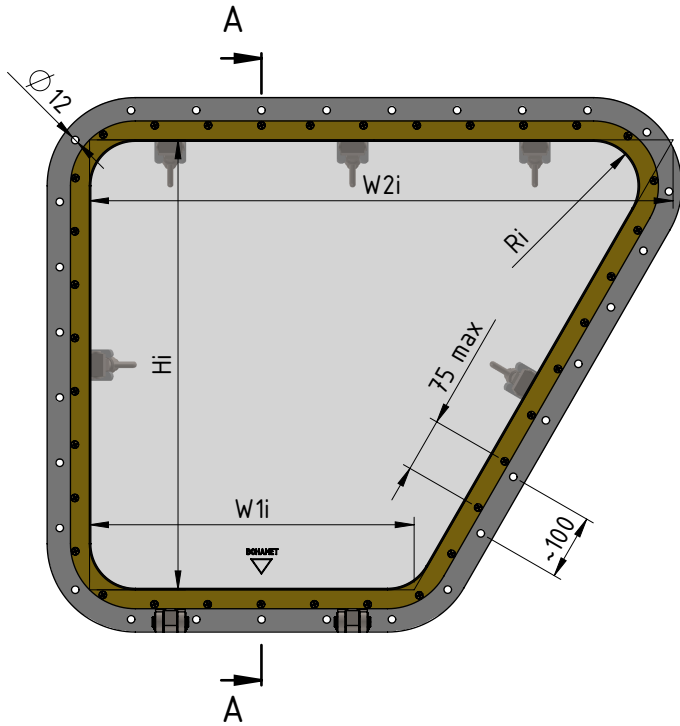

MATERIALS CONFIGURATION								
MAIN FRAME	MOVEABLE FRAME				GLASS RETAINING		SCREWS	
	1	2	3	4	2	4*	2	4*
1	X	X	X	X	X	X	X	X
2	X	X	X	X	X	X	X	X
3	X	X	X	X	X	X	X	X
4	X	X	X	X	X	X	X	X

Not available for the aluminum moveable frame

- 1. Steel (acc. to PN-EN10025): S235JR; S355J2; A36; D36; E36
- 2. St. steel (acc. to PN-EN10088): 1.4306 (304L); 1.4404 (316L); 1.4457 (316Ti)
- 3. Alu. alloy (acc. to PN-EN755): EN-AW 5754; EN-AW 5083; EN-AW 6063; EN-AW 6060
- 4. Brass (acc. to PN-EN12167): CuZn37

Typical radius Ro: R75, R100, R125

Available glass: single glass; laminated glass; tinted glass; heated glass; double glazed; triple glazed

Available single glass thicknesses: 6; 8; 10; 12; 15; 19; 25

Available accessories for windows: S; D; R; W; C; G; H - see accessories TDS

For fireproof unit see separate TDS

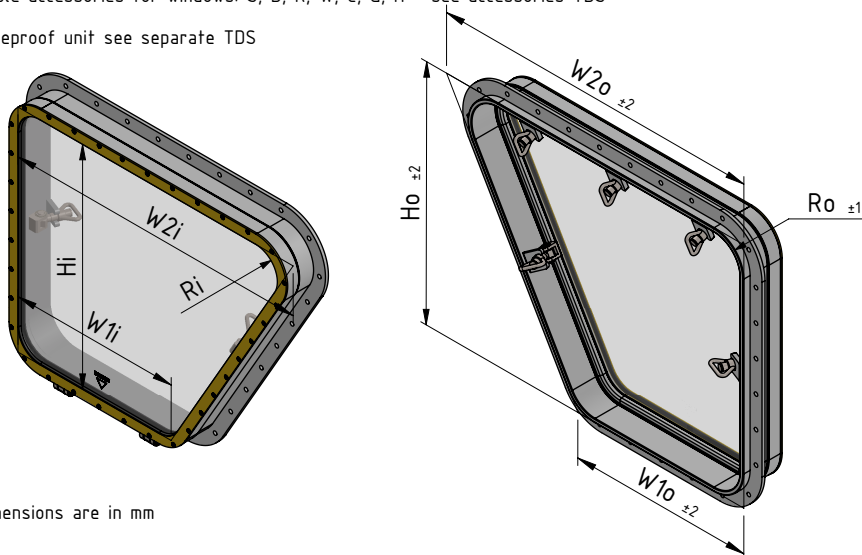

CUT-OUT HOLE IN PLATE (HIP)

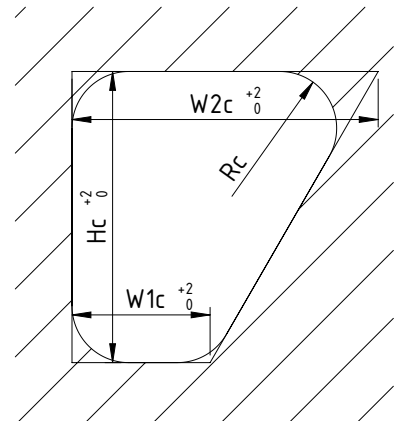

All dimensions are in mm