

TOP INWARD HALF OPENING WINDOW FOR WELDING, RECTANGULAR

model: W-ITW-H-RC

A-A

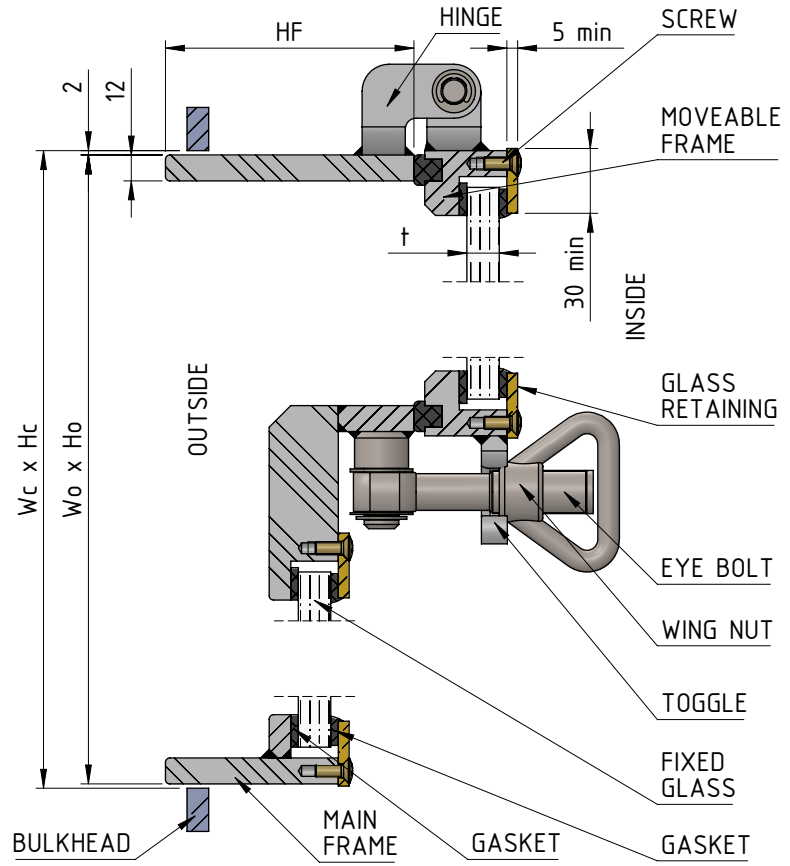
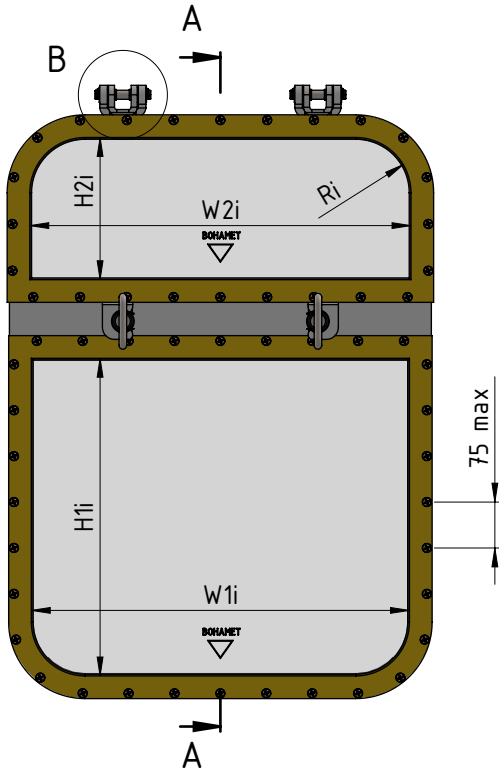

MATERIALS CONFIGURATION								
MAIN FRAME	MOVEABLE FRAME				GLASS RETAINING		SCREWS	
	1	2	3	4	2	4*	2	4*
1	X	X	X	X	X	X	X	X
2	X	X	X	X	X	X	X	X
3	X	X	X	X	X	X	X	X
4	X	X	X	X	X	X	X	X

Not available for the aluminum moveable frame

1. Steel (acc. to PN-EN10025): S235JR; S355J2; A36; D36; E36
2. St. steel (acc. to PN-EN10088): 1.4306 (304L); 1.4404 (316L); 1.4457 (316Ti)
3. Alu. alloy (acc. to PN-EN755): EN-AW 5754; EN-AW 5083; EN-AW 6063; EN-AW 6060
4. Brass (acc. to PN-EN12167): CuZn37

Typical radius R_o : R75, R100, R125

Available glass: single glass; laminated glass; tinted glass; heated glass; double glazed; triple glazed

Available single glass thicknesses: 6; 8; 10; 12; 15; 19; 25

Available accessories for windows: S; D; R; W; C; G; H - see accessories TDS

For fireproof unit see separate TDS

Hinge configurations:

Detail B1
Hinge $\varnothing 12$

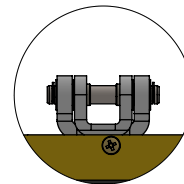

Detail B2
Hinge $\varnothing 16$

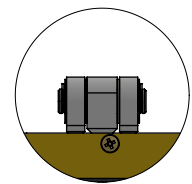

CUT-OUT HOLE IN PLATE (HIP)

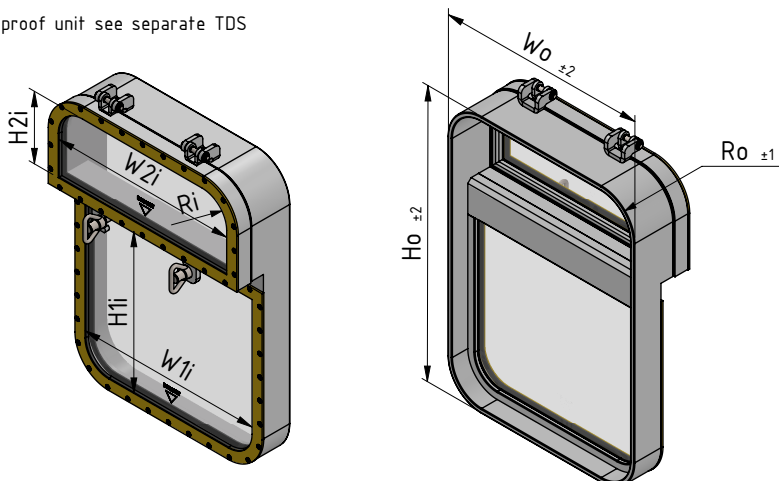
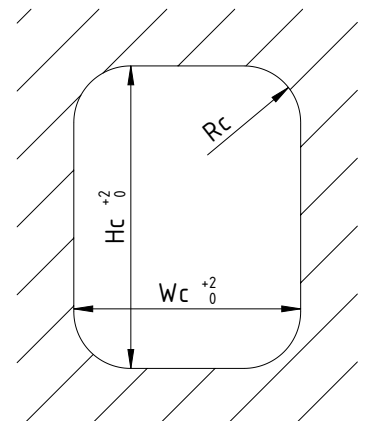

All dimensions are in mm