

# NON OPENING WINDOW FOR BOLTING, OVAL

model: W-NOB-OV

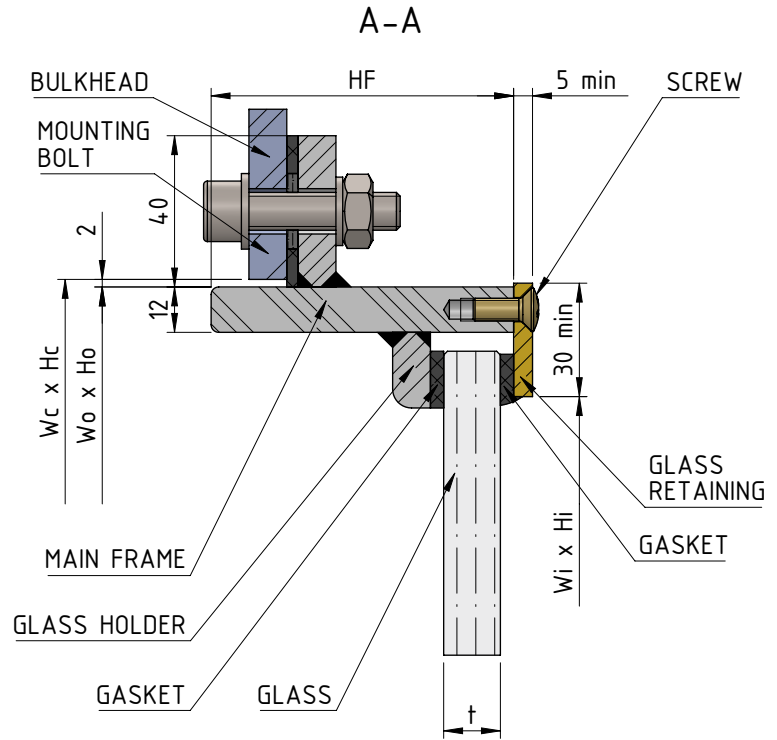
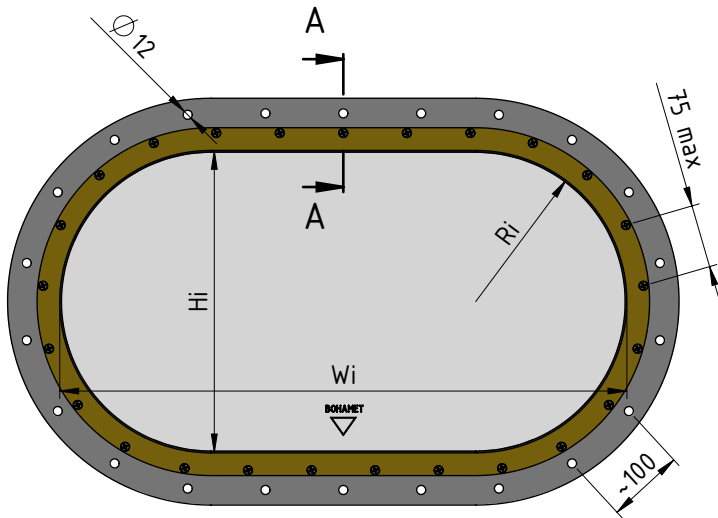

MATERIALS CONFIGURATION								
MAIN FRAME	GLASS HOLDER				GLASS RETAINING		SCREWS	
	1	2	3	4	2	4	2	4
1	X	X			X	X	X	X
2		X			X	X	X	X
3			X		X		X	
4				X	X	X	X	X

1. Steel (acc. to PN-EN10025): S235JR; S355J2; A36; D36; E36
2. St. steel (acc. to PN-EN10088): 1.4306 (304L); 1.4404 (316L); 1.4457 (316Ti)
3. Alu. alloy (acc. to PN-EN755): EN-AW 5754; EN-AW 5083; EN-AW 6063; EN-AW 6060
4. Brass (acc. to PN-EN12167): CuZn37

Available glass: single glass; laminated glass; tinted glass; heated glass; double glazed; triple glazed

Available single glass thicknesses: 6; 8; 10; 12; 15; 19; 25

Available accessories for windows: S; D; R; W; C - see accessories TDS

For fireproof unit see separate TDS

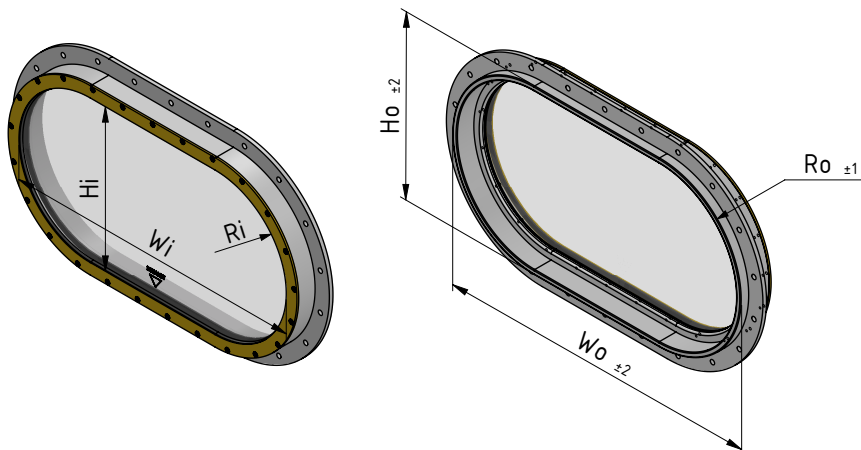

## CUT-OUT HOLE IN PLATE (HIP)

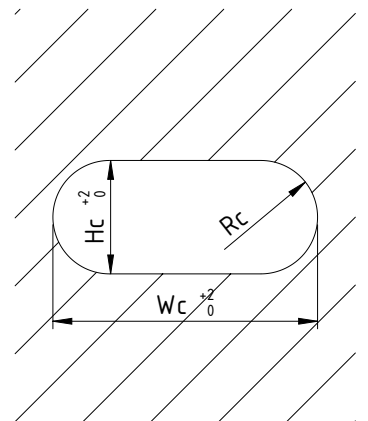

All dimensions are in mm